

Project: Penn Station, New York City

Product: Spectraglass

Architect: Skidmore, Owings & Merrill LLP (SOM)
 Contractor: Skanska

Date completed: October 2017

Project Description

- Skyscape is a bespoke light art installation, spanning the length of the ceiling at the new west end concourse of the Moynihan Train Hall, Penn Station, New York City.
- Designed by Skidmore, Owings & Merrill LLP (SOM) for client Moynihan Station Development Corporation, with lighting design & manufacture by The Light Lab, in collaboration with artists miriamandtom.
- The Light Lab were commissioned to work on the design and build of this 'digital sky', using their bespoke edge lit glass product Spectraglass. The Light Lab designed & manufactured an easy-fit support structure and LED glass fins to fill the expanse of the 15'x300' ceiling.
- The brief included making all the services above the fins easily accessible, so the design mounted the fins on easy slide carriages on precision rails.
- The 2,000 pixels of RGBW LED light, softened through the glass, gives a gentle, calming sense of space in an otherwise confined and overcrowded space and has been very well received by the harassed commuters, as they wait for the full redevelopment of the station.

Architect's render



The Light Lab are able to make installations that comply with stringent health & safety and building regulations that are reliable and low maintenance, which are typical when working on transport hubs.

There were also certain rules about electromagnetic interference (EMI) and radio frequency interference (RFI) – which were very strict in particular for the Penn Station project.

For example, in New York City, as 6 different law enforcement agencies have their own communication systems, these could not in any way be interfered with by our kit – and this was exhaustively tested and established at Penn.

Project images

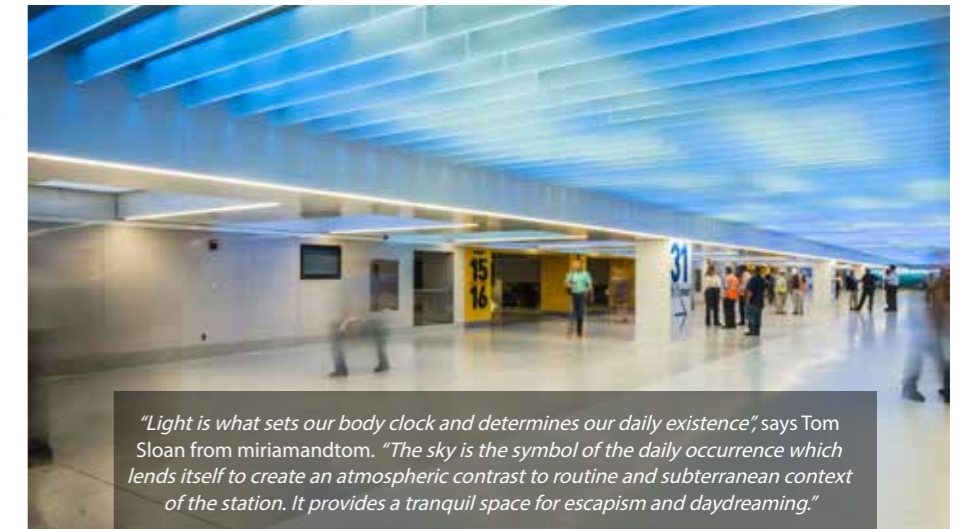

"Light is what sets our body clock and determines our daily existence," says Tom Sloan from miriamandtom. "The sky is the symbol of the daily occurrence which lends itself to create an atmospheric contrast to routine and subterranean context of the station. It provides a tranquil space for escapism and daydreaming."

Glass detail

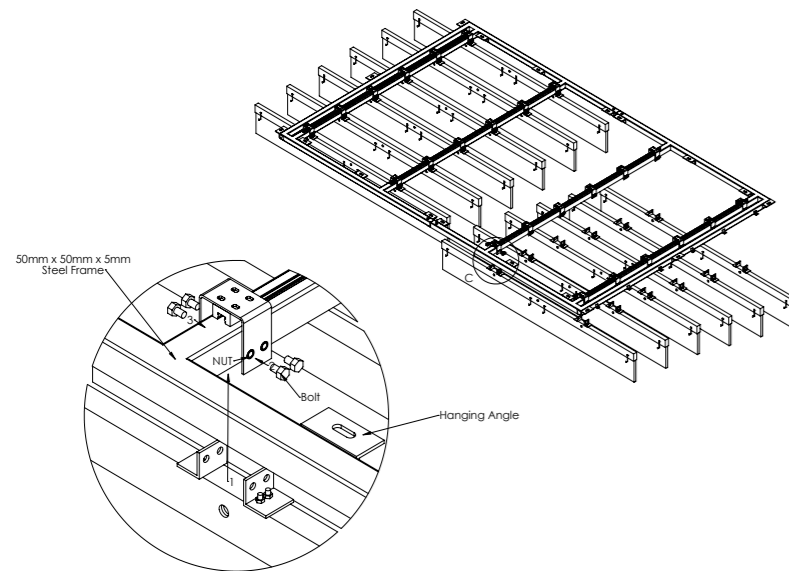

Runner detail

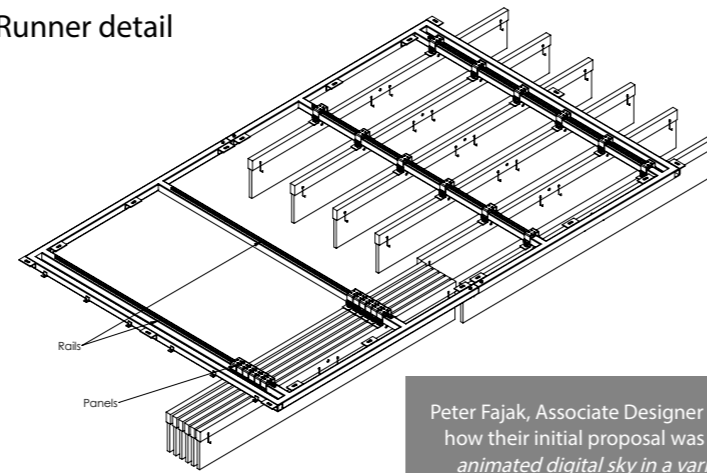

Peter Fajak, Associate Designer at SOM, describes how their initial proposal was to "create a fully animated digital sky in a variety of different media with edge lit glass fins, back lit ceilings and digital media screens." Effectively 'bringing the sky' and an "above ground quality" to the dark underground transit tunnel; "Filling an underground world with sky & light, to transform it into a habitable environment."

Box section install

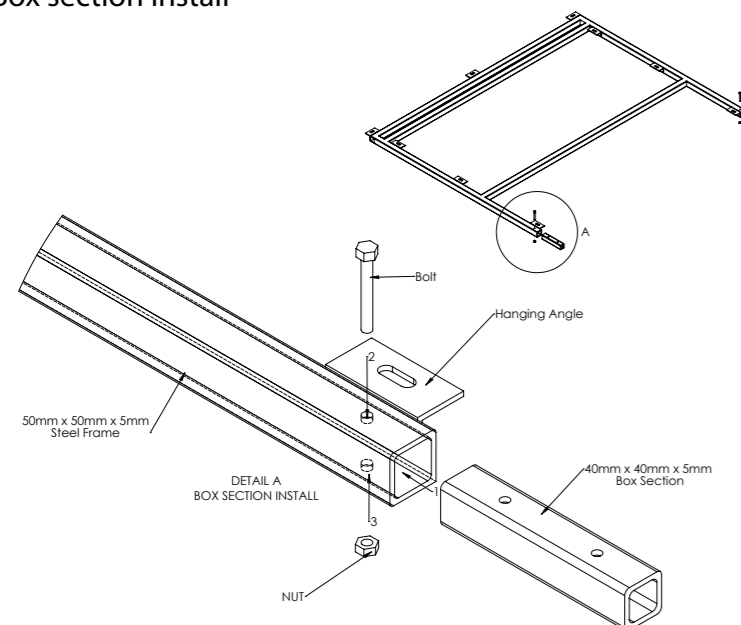

Frame install

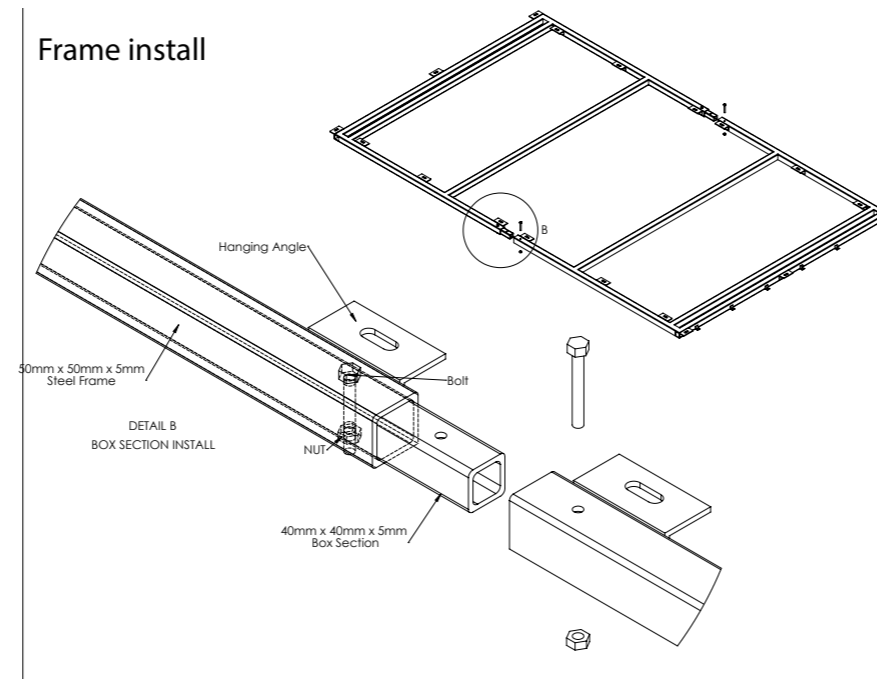

Specification Spectraglass

Height:
LED:

The Light Lab
 22 Holywell Row
 London EC2A 4JB
 United Kingdom

+44 (0) 207 278 2678
www.thelightlab.com

Company Reg. No: 4406351
 Reg. Office: 22 Holywell Row, London EC2A 4JB

the light lab
 bright ideas